

## Holder / No. 862

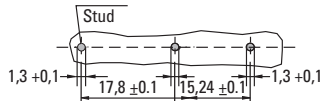

Horizontal / 2-Pin



Holes in the printed circuit board: 1,3 ± 0,1

## PC Mount, Shocksafe 5x20mm / 6.3x32mm Fuses

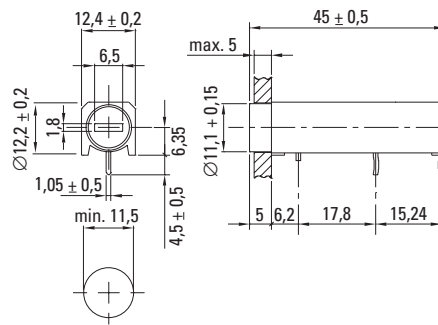

## Specifications

### Standard

IEC 60127-6  
UL 512  
CSA C22.2. No.39

### Approvals

VDE: Report No. 136720 ÜG  
SEMKO: Certificate No. 201675  
UL Recognized: File No. E70164  
CSA Certified: File No. 208327



### Mounting

(2) Solder pins 0.5mm x 1.1mm and plastic stud  
Pins are kicked for optimal soldering

### Protection Class & Category

IP 40 (IEC 60529)  
PC2 (IEC 60127-6)

### Materials

Holder/Cap: Black Duroplast, UL 94V0  
Metal Parts: Copper alloy, corrosion protected  
Terminals: Solderable, tinned

### Electrical Data (23°C)

Rated Voltage: 250V  
Rated Current: 6.3A (SEMKO)  
10A (VDE)  
16A (UL/CSA)  
Rated Power: 862/865: 2.5W (VDE)  
862/866: 3.2W (VDE)  
1.6W (SEMKO)

### Operating Temperature

-40°C to +85°C (consider de-rating)

### Climatic Test

-40°C/+85°C/21 days (IEC 60068-2-1...3)

### Stock Conditions

+10°C to +60°C  
relative humidity ≤ 75% yearly average,  
without dew, maximum value for 30 days - 95%

### Vibration Resistance

24 cycles at 15 min. each (IEC 60068-2-6)  
10 - 60Hz at 0.35mm amplitude  
60 - 500Hz at 5g acceleration

### Contact Resistance

≤ 5mΩ

### Impulse Voltage

4 kV, 50 Hz, 1 min., dry

### Insulation Resistance

> 10<sup>3</sup> MΩ (500 VDC, 1 min.)

### Solderability

235°C, 2 sec. (Wave)  
350°C, 1 sec. (Soldering Iron)

### Soldering Heat Resistance

350°C, 5 sec. (IEC 60068-2-20)

### Minimum Cross Section

Conducting path - 0.2mm<sup>2</sup>

### Marking

862, 250V, Approvals

### Unit Weight

5.6g (862) / 3.3g (865) / 2.5g (866)

## Cap / No. 865



For 5x20mm Fuses

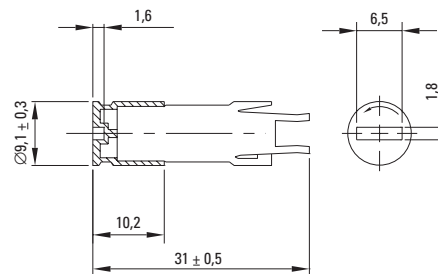

## Cap / No. 866



For 6.3x32mm Fuses

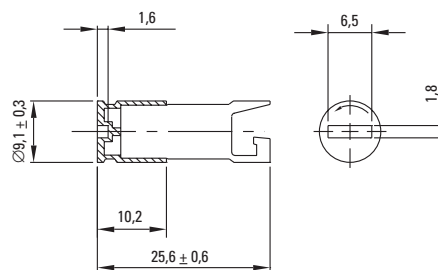

## Order Information

### Packaging

Bulk (100 pcs.)

### Order Numbers

Holder	No. 862 0000 100
Cap, 5x20mm	No. 865 0000 100
Cap, 6.3x32mm	No. 866 0000 100

## WebLinks

### Data Sheet - latest version

[www.wickmannusa.com/products/862.pdf](http://www.wickmannusa.com/products/862.pdf)

### Approval Certificates

[www.wickmannusa.com/approvals](http://www.wickmannusa.com/approvals)

### For Application Information refer to

[www.wickmannusa.com/download/fuseology.pdf](http://www.wickmannusa.com/download/fuseology.pdf)

Specifications are subject to change without notice.